

● Crystal Resonator (晶体谐振器) – SMD Type (表贴型)

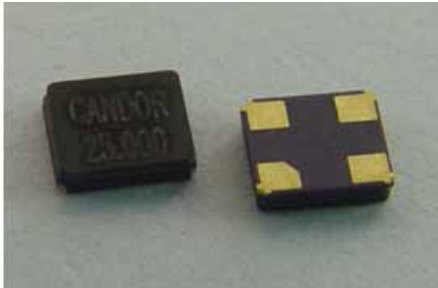

● Applications 用途:

Bluetooth, DSC, Notebook, etc (蓝牙, 数码相机, 笔记本电脑, 等等)

● Features 特征:

- A version of leadless type surface mount crystal unit. 无引线表面贴装晶体。
- High precision and high frequency stability. 高精度及高稳定性。
- Reflow Soldering. Emboss tape & reel. 回流焊. 编带包装。

● Typical specifications 规格参数

Frequency range(Fund.)(基频)	频率范围	12,000-50,000MHz		
Vibration mode	振荡模式	AT cut		
Frequency tolerance(at +25℃)	调整频差	$\pm 10, \pm 20, \pm 30 \times 10^{-6}$		
Frequency stability	温度频差	$\pm 10 \times 10^{-6}$	$\pm 15 \times 10^{-6}$	See Table1 (见表 1)
Opera temperature range	工作温度	-10 ~ +60℃	-30 ~ +85℃	See Table1 (见表 1)
Equivalent series resistance	等效电阻	See Table2 (见表 2)		
Load capacitance	负载电容	series, 9pF, 10pF, 12pF, 16pF, 20pF, 30pF, etc.		
Shunt capacitance	静电容	5pF max.		
Level of drive	激励功率	10μW(100μW max.)		
Aging	老化率	$\pm 1, \pm 3$ ppm/year		
Storage temperature range	储存温度	-55 ~ +125℃		

- Please consult for other specifications. (若有其它规格需求请告知)

● Outline Dimensions [Unit: mm] 外形尺寸

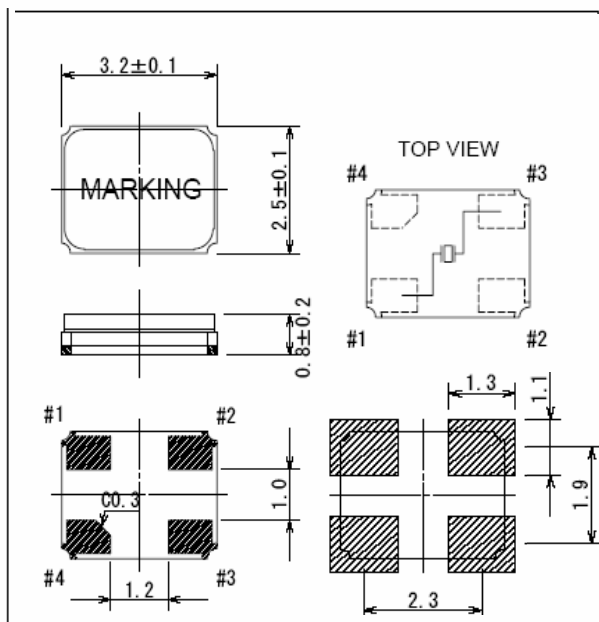

● Table1: Frequency stability (ref. to 25℃) 频率稳定性

O.P Temp.	± 2.5 ppm	± 5 ppm	± 10 ppm	± 20 ppm	± 30 ppm
0 ~ +50℃			●	●	●
-10 ~ +60℃			●	●	●
-20 ~ +70℃			●	●	●
-40 ~ +85℃				●	●

● Table2: Equivalent series resistance (ESR) 等效电阻

频率 Frequency (MHz)	ESR(Ω)
12.0-13.9 Fund.	120
14.0-16.0 Fund.	100
16.001-26.0 Fund.	80
26.001-50 Fund.	50